

The use of ice to cool the concrete mix in the construction of massive structures

N. A. Aniskin¹, Trong Chuc Nguyen^{2,*}, Anh Kiet Bui³

¹National Research Moscow State University of Civil Engineering, d. 26, YaroslavscoeShosse, Moscow, 129337, Russian Federation

²Le Quy Don Technical University, Hanoi 100000, Vietnam

³Ho Chi Minh City Open University, Vietnam

* Email: ntchuc.mta198@gmail.com

Abstract. This article proposes a formula in order to determine the required amount of ice to partially replace the water in the concrete mix to control the initial temperature of the concrete mix and reduce possible cracking. The formula was created based on the principle of energy balance in the heat transfer process. At the same time, the obtained results were compared with the other methods. Besides, an example of the calculation for a concrete block during the construction was performed. The maximum temperature and temperature difference in mass concrete obtained depend significantly on the initial temperature of the concrete mixture. The research results and the proposed techniques can be used in the practical design of mass concrete structures.

1. Introduction

The construction of massive concrete structures such as dams, foundations, and bridge supports requires the use of a large volume of cement as a binder. In such structures, which have a small value of the ratio of its surface area and volume, the process of removing the heat released during hydration from the inside to the outside of the surface of the structure slows down, and the risk of thermal cracking increases [1-3]. Advanced concrete technology has created high-performance concrete with a large cement content, which increases the curing process and also shortens the construction schedules. At the same time, when placing concrete with a large amount of cement, it will lead to a temperature peak as well as the temperature difference between the center and the surface of the concrete block will increase. Therefore, this in turn leads to thermal cracking at an early age [4-6].

To minimize the formation of thermal cracks by controlling the main factors that influence the temperature regime in mass concrete structures. These include the consumption of cement and its heat release, the time of concrete placement, the thickness of the concrete placement, the initial temperature of the concrete mixture, etc [7-10].

In the practice of building mass concrete, measures commonly used to prevent the formation of thermal cracks in mass concrete structures include [11]:

- + use of low-heat cement or replace cement with some other material (fly ash, slag, etc) to reduce the degree of exothermic heating of the concrete mixture being laid [12];
- + use chemical additives to slow down and reduce heat generation in the hydration of cement [13];
- + the choice of the moment of concrete placement (both the season and the time of day). In particular, placing concrete at night or in the early morning has several advantages - in particular,

reducing the exposure to solar radiation in the early hours after concrete placement; placing concrete in the cold season in this sense is also often preferable [14, 15];

+ using a cooling pipe system to reduce the temperature inside the concrete block [16,17];

+ use surface insulation to reduce the temperature difference between the central zone and the surface of the concrete block (it can be used during construction both in winter and summer). When built in the winter, the surface insulation works to prevent rapid cooling of the concrete block surface. In contrast, when built in the summer, the surface insulation prevents the warming of the concrete block surface [11];

+ reducing the thickness of the poured layer can reduce the maximum temperature in the concrete block. However, the reduction of the pour layer thickness can affect the construction progress and project cost [11].

All the above measures to reduce the maximum temperature inside the concrete block require a detailed study of the economic feasibility analysis [11].

There are many ways to reduce the initial temperature of concrete mixes such as lowering the temperature of the aggregate, using liquid nitrogen to reduce the concrete mix, using cool water, or using ice instead of part of the water.

Cooling a concrete mixture with liquid nitrogen is one of the most effective means to reduce the temperature of the concrete mixture to (30-35)°C. However, this is a costly method due to the requirement of special equipment to spray liquid nitrogen gas into the concrete mix. The above method is used only in extreme cases. The most economical and easiest to apply method is to cool by water and especially to partially replace the water with ice. In this case, an important task is to correctly determine the required amount of ice. The work of a number of researchers is devoted in order to determine the amount of ice required to obtain the value of the required temperature for the concrete mixture [11].

In this paper, use the principle of energy balance to determine the amount of ice required to partially replace the water and obtain the initial temperature of the desired concrete mixture. A formula is proposed for determining the required amount of ice to obtain a concrete mixture with the required initial temperature. At the same time, the study results are compared with the recommendations of other authors. The research results show good agreement with laboratory experiments and previously obtained results indicate the reliability of the results. Therefore, the study results can be used when designing and controlling the formation of thermal cracks in mass concrete structures.

2. Materials and methods

This research is carried out based on the basic laws of physics. In particular, the law of conservation of energy in the heat transfer process has been applied. The numerical calculations were performed by Midas software with a program algorithm based on the theory of heat conduction and convection heat transfer.

2.1. Determination of the initial temperature for the concrete mix

The available methods for determining the initial temperature of concrete mixtures depend on the composition and the temperature of the components. This is a simple method and is based on the energy balance theory. In accordance with the standards of the Japan Concrete Institute [18] "Concrete Mass Cracking Control Guide 2016", the formula for determining the initial temperature of a concrete mixture is as follows:

$$T_o = \frac{c_1(m_c T_c + m_a T_a + m_s T_s) + c_2 m_w T_w}{c_1(m_c + m_a + m_s) + c_2 m_w}, \quad (1)$$

where: m_i ($i=c, a, s, w$) - mass of the i -th component of the concrete mixture per 1 m³ of concrete mixture, kg/m³ (c, a, s, w - symbols for cement, coarse aggregate, sand and water, respectively); T_i ($i=c, a, s, w$) - the temperature of the i -th aggregate in the concrete mixture, °C; c_1 - specific heat capacity of cement and

aggregate (they are approximately equal in value), kcal/(kg.°C); c_2 - the specific heat capacity of water, kcal/(kg.°C).

Taking into account that $c_c = c_a = c_s = c_1 \approx 0.2$ kcal/(kg.°C), and $c_2 \approx 1.0$ kcal/(kg.°C), formula (1) can be written as follows [18]:

$$T_o = \frac{0.2(m_c T_c + m_a T_a + m_s T_s) + m_w T_w}{0.2(m_c + m_a + m_s) + m_w}, \quad (2)$$

The referenced standard states that in order to lower the temperature of concrete by 1°C, it is usually necessary to lower the temperature of the cement, aggregate or mixing water by about 8°C, 2°C and 4°C, respectively.

When using ice to cool water, the temperature drop ΔT of concrete mixture is determined by formula (3) [18]:

$$\Delta T = \frac{m_{ice} \{79.6 + (T_o - 0)\}}{0.2(m_c + m_a + m_s) + m_w} E_f, \quad (3)$$

where: m_{ice} - mass of ice (kg/m³); E_f - cooling efficiency (can be taken as 0.7-0.8).

However, the above formula does not fully consider the nature of the energy transfer process. In addition, in the case of using ice to cool the water, the amount of ice needed to reduce the initial temperature of the concrete mixture has not been determined.

That takes an effort to determine the amount of ice required to obtain a given initial temperature of the concrete mix. In this case, it is also necessary to ensure the W/C ratio required to obtain concrete of the desired composition.

2.2. Method for determining the amount of ice required to cool the concrete mixture

We consider the thermal balance of a concrete mixture. Symbols, masses of each component and their thermal properties are shown in Table 1.

Let's denote by x the unknown amount of ice in kilograms used to cool the concrete mixture. Then the required amount of water at the accepted value of the water-cement ratio W/C will be equal to $(\alpha \times m_c - x)$. Let's take the ice temperature equal to 0°C. We take the specific heat of melting of ice $\lambda = 81.26$ (kcal/kg) [18]. The initial temperature of the concrete mixture after mixing is denoted T_o . Each of the i components of the concrete mixture, before mixing, has a temperature of T_i , respectively.

Table 1. Mixture proportions of concrete

Parameters	W/C	Cement	coarse aggregate	Sand	water	ice
Weight, kg	α	m_c	m_a	m_s	$\alpha \times m_c - x$	x
Specific heat, kcal/(kg.°C)	-	c_c	c_a	c_s	c	-
Temperature, °C		T_c	T_a	T_s	T_w	0

Then the amount of thermal energy when the temperature of the components decreases to the initial temperature of concrete T_o , will be equal to:

$$Q_A = \sum_i c_i m_i (T_i - T_o), \quad (4)$$

Substituting the symbols according to Table 1, we obtain equation (5):

$$Q_A = c_c m_c (T_c - T_o) + c_a m_a (T_a - T_o) + c_s m_s (T_s - T_o) + c_w (\alpha m_c - x) (T_w - T_o) \quad (5)$$

The heat required for thawing the ice and the transition of the temperature of the formed water from 0°C to the temperature T_o will be:

$$Q_B = \lambda m_{ice} + c_w m_{ice} (T_o - 0) = \lambda x + c_w x T_o \quad (6)$$

According to the principle of heat balance, equality can be written: $Q_A = Q_B$, or

$$c_c m_c (T_c - T_o) + c_a m_a (T_a - T_o) + c_s m_s (T_s - T_o) + c_w (\alpha m_w - x) (T_w - T_o) = \lambda x + c_w x T_o \quad (7)$$

From equation (7), the amount of ice required to partially replace water to obtain the initial temperature of the T_o concrete mixture was determined and presented as equation (8).

$$x = \frac{c_c m_c (T_c - T_o) + c_a m_a (T_a - T_o) + c_s m_s (T_s - T_o) + c_w \alpha m_w (T_w - T_o)}{\lambda + c_w T_w} \quad (8)$$

Assuming that the temperature of the components of the concrete mixture is taken approximately equal to the air temperature ($T_c = T_a = T_s = T_w = T_{air}$) and $c_c = c_a = c_s \approx 0.2$ kcal/(kg.°C), $c_w \approx 1.0$ kcal/(kg.°C). Equation (8) can be written simply as follows:

$$x = \frac{[0.2(m_c + m_a + m_s) + \alpha m_c](T_{air} - T_o)}{\lambda + T_{air}} \quad (9)$$

3. Results and Discussion

3.1. Determine the amount of ice required to cool the concrete mixture

The proposed formula was applied to the estimation of the temperature control of the concrete mass due to the initial temperature of the concrete mixture. The composition of the concrete mixture used for the construction of the massif is presented in Table 2 [19]. Average temperature of the air $T_{air} = 20^\circ\text{C}$. Determine the amount of ice required to obtain the initial temperature of the concrete mixture is 16°C .

Table 2. The composition of the concrete mix

Mixing proportions	W/C	Cement, kg/m ³	Aggregate, kg/m ³	Water, kg/m ³	ice, kg/m ³
	0.5	350	1814	175 - x	x

Using the resulting formula (9), the required amount of ice water is obtained:

$$x = \frac{[0.2(m_c + m_a + m_s) + \alpha m_c](T_{air} - T_o)}{\lambda + T_{air}} = \frac{[0.2(350 + 1814) + 0.5 \times 350](20 - 16)}{81.26 + 20} = 24.01 \quad (10)$$

Thus, the volume of water at the initial temperature is equal to the air temperature (20°C) is $175 - 24.01 = 150.99$ kg.

Let us determine the water temperature under the conditions considered.

The amount of heat required to reduce the water temperature from 20°C to T_w is:

$$Q_1 = c_w m_w (T_{air} - T_w) = 150.99(20 - T_w) \quad (11)$$

The amount of heat required to melt ice and increase its temperature from 0°C to T_w is:

$$Q_2 = \lambda m_{ice} + c_w m_{ice} (T_w - 0) = 81.26 \times 24.01 + 24.01 T_w = 1951.05 + 24.01 T_w \quad (12)$$

According to the principle of energy balance $Q_1 = Q_2$.

$$150.99(20 - T_w) = 1951.05 + 24.01 T_w, \quad (13)$$

then we receive it $T_w = 6.1^\circ\text{C}$.

With similar data, according to published research results, the water temperature after mixing with ice is 5°C [19].

The difference between the author's results and the previous study is explained by the lack of details of the experiment performed in the study [19]. In addition, in this study, the approximate values of the specific heat capacities (c_i) and the melting point of ice (λ) were taken, which could lead to a deviation of the results obtained. In addition, heat loss is inevitable when interacting with the environment.

In order to compare with other research results, the calculations were performed according to the recommendations of the standards of the Japanese Institute of Concrete [18]. According to this recommendation, the reduced temperature of the concrete mixture after mixing with ice is:

$$\Delta T = \frac{m_{ice} \{79.6 + (T_o - 0)\}}{0.2(m_c + m_a + m_s) + m_w} E_f = \frac{24.01 \{79.6 + 20\}}{0.2(350 + 1814) + 150.99} \times 0.8 = 3.24^\circ C \quad (14)$$

According to the method described in this work - $\Delta T = 20 - 16 = 4^\circ C$.

Differences between the calculation results can be explained by differences in the parameters in the calculation.

3.2. The influence of the initial temperature of the concrete mixture on the temperature regime in mass concrete

In this paper, consider the effect of the initial temperature of the concrete mixture on the temperature regime of a concrete block with the size of 8m×6m×3m. This concrete block is placed on the foundation with the dimensions of 16m×12m×4m. The calculation diagram and finite element model are shown in Figure 1 (1/4 meshed model of finite element). The characteristics of concrete and foundation accepted in the calculations are presented in Table 3. Wooden formwork with a thickness of 2.5 cm and horizontal surface insulation was used.

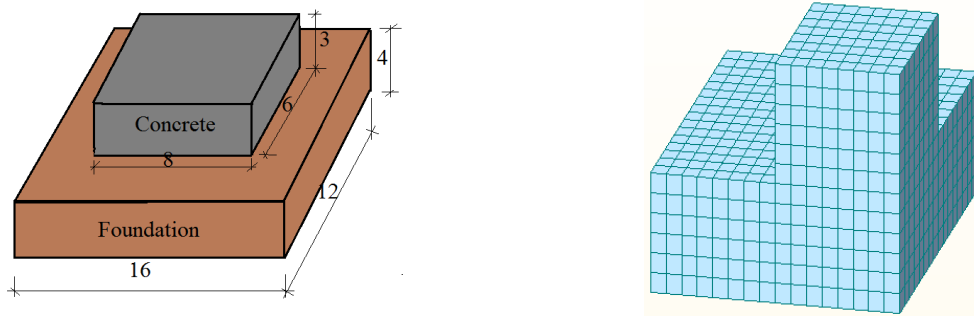

Figure 1. Design block diagram and FEM mesh

Table 3. Calculated physical characteristics of materials

No	Characteristics, units	Values	
		Concrete	Foundation
1	Thermal conductivity coefficient, W/(m.°C)	2.60	2.00
2	Specific heat, kJ/(kg.°C)	0.95	0.84
3	Density of material, kg/m ³	2400	2650
4	Convective heat transfer coefficient, W/(m ² .°C)	2.6	14.00
5	Modulus of elasticity, N/m ²	2.7×10 ¹⁰	1.8×10 ¹⁰
6	The coefficient of linear thermal expansion	1×10 ⁻⁶	1×10 ⁻⁵
7	Poisson's ratio	0.18	0.20

Equivalent convective heat transfer coefficient on a surface with wooden formwork is $h_{eq} = 2.6$ W/(m².°C) [20]. The convective heat transfer coefficient of the surface with insulation is 0.66 W/(m².°C). Consider the composition of the concrete mix is presented in Table 2. The average temperature of the air $T_{air} = 20^\circ C$. Let us determine the amount of ice required for the initial temperature of the concrete mixture equal to 5, 10, 12 and 16°C.

Table 4. The amount of ice required to cool the concrete

Initial concrete temperature T_o , °C	5	10	12	16	20
ice - x, kg/m ³	90.04	60.02	48.02	24.01	0
Water, kg/m ³	84.96	114.98	126.98	150.99	175
% of the volume of ice instead of water	51.45%	34.29%	27.44%	13.72%	0%

According to the proposed formula Equation (9), for each design case, the amount of ice required to obtain the initial temperature of the concrete mixture is determined. The calculation results are presented in Table 4.

Thus, in order to lower the temperature of the concrete mixture of the considered composition from 20°C to 5°C, it is necessary to replace 51.45% of the volume of water with ice (which is 90 kg per cubic meter).

With the help of Midas civil software for the calculated domain was considered and different values of the initial temperature of the concrete mixture. The maximum temperature, the temperature difference between the center and the surface of the concrete block have been determined. The obtained results are shown in Table 5 and the graph is presented in Figure 2.

Table 5. Influence of the initial temperature of the concrete mixture on the maximum temperature and temperature drops

T_o	5	10	12	16	20
T_{max}	57.91	63.66	65.86	70.16	74.33
ΔT_1 = between center and side surface	17.17	19.71	20.62	22.37	24.09
ΔT_2 = between center and top surface	3.03	3.65	4.05	4.39	4.85
Time to reach maximum temperature, h	168	132	120	96	84

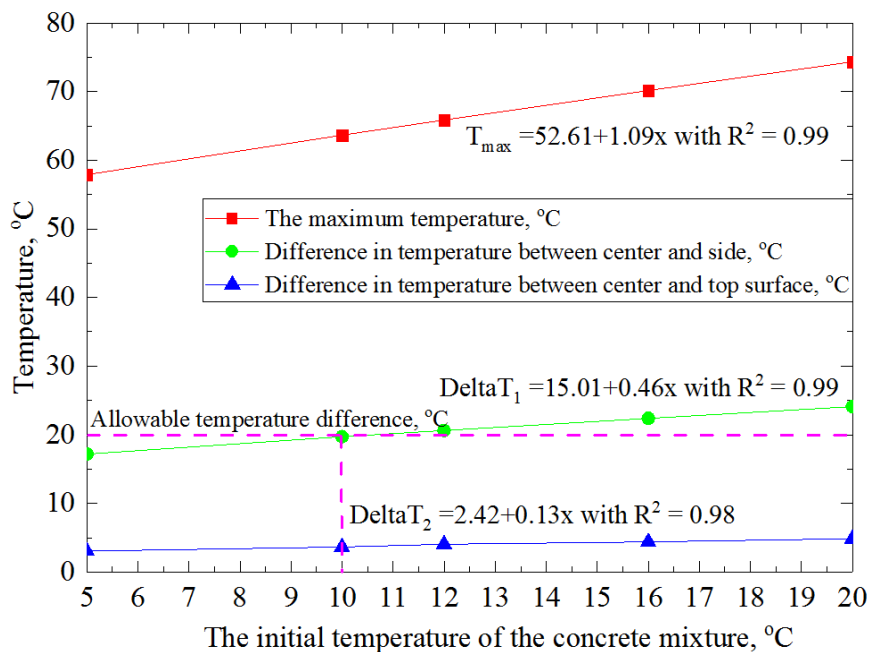

Figure 2. Change in maximum temperature and temperature differences depending on the initial temperature of the concrete

4. Conclusions

Based on the results obtained, the following should be noted:

(1) When using cooling water to prepare concrete mix is a fairly affordable and cost-effective method to reduce heat generation in mass concrete structures. The effect can be increased by replacing a certain amount of water with ice.

(2) By adjusting the amount of ice, it is possible to obtain the initial temperature of the concrete mixture, the maximum temperature, and the temperature difference to reach the desired value. This avoids the formation of temperature cracks.

(3) A simple formula is proposed in order to determine the required amount of ice with the given parameters and concrete composition.

(4) Use Midas software to determine the maximum temperature and the temperature difference in mass concrete. The results obtained show that the values of the maximum temperature, the temperature difference depend on the initial temperature of the concrete mixture. The relationship of the maximum temperature, the temperature difference with the concrete mixture initial temperature is linear. To ensure that the temperature difference between the center and the surface of the concrete block does not exceed 20°C (according to the requirements of crack resistance), the initial temperature of the concrete mixture under the conditions under consideration should not exceed 10°C. That means, under consideration, the minimum required amount of ice water is 60kg/m³.

(5) The initial temperature of the concrete mixture affects the time of occurrence of the maximum temperature in the mass concrete structure. So, for the considered case, the time of occurrence of the maximum temperature at an initial concrete temperature of 10°C is 132 hours after laying, and at 20°C - 84 hours. In addition, when the initial temperature of the concrete mixture decreases, the strength development of the concrete may decrease. This should be considered in the technological process.

(6) The proposed method in order to calculate the required amount of ice for cooling the constructed concrete mass can be used in the design of the technology for concreting massive structures.

References

- [1] SP41.13330.2012 2012 *Concrete and reinforced concrete structures of hydraulic structures* (Moscow: Ministry of Regional Development of Russia) 115 p (In Russian)
- [2] ACI 207.1R-96 1996 *Mass Concrete* (Reported by ACI Committee 207)
- [3] ACI 207.1R-05 2005 *Guide to Mass Concrete* (Reported by ACI Committee 207)
- [4] Aniskin N A, Nguyen T C, Hoang Q L 2018 *MATEC Web of Conferences* **251**, 02014
- [5] Aniskin N A, Nguyen T C, Bryansky I A, Dam H H 2018 *Vestnik MGSU* **13**(11) 1407-1418
- [6] Tang Hao, Cai De-Suo, Yang Li 2013 *Applied Mechanics and Materials* **300-301** 1584-1588
- [7] Jin Keun Kim, Kook Han Kim, Joo Kyoung Yang 2001 *Computers and Structures* **79** 163-171
- [8] Kuzmanovic V, Savic L, Mladenovic N 2013 *Journal of Thermal Stresses* **36**(2) 112-134
- [9] Joo-Kyoung Yang, Yun Lee, Jin-Keun Kim 2011 *Journal of Advanced Concrete Technology* **9**(1) 103-114
- [10] Li B, Wang Z, Jiang Y, Zhu Z 2018 *Advances in Mechanical Engineering* **10**(1) 1-15
- [11] Aniskin N A, Nguyen T C 2020 *Vestnik MGSU* **15**(3) 380–398
- [12] Kim S G 2010 *Effect of heat generation from cement hydration on mass concrete placement* (Graduate Theses and Dissertations, Iowa State University)
- [13] Wenqiang Xu, Sheng Qiang, Zhengkai Hu, Bingyong Ding, Bingyong Yang 2020 *Advances in Civil Engineering* 17p
- [14] Aniskin N A, Nguyen T C, Le D A 2020 *Power Technology and Engineering* **54** 1–6
- [15] Dadiani N Z 2018 *Power Technology and Engineering* **6** 49-54
- [16] Nguyen T C, Nguyen T S, Nguyen Q V, Do T M D 2020 *Structural integrity and life* **20**(2) 131–135
- [17] Wen C L, Wan L C, Hui Q Y, Tian X Y, Wang J 2016 *Applied Science* **110**(6) 18p
- [18] Japan Concrete Institute 2016 *Guidelines for Control of Cracking of Mass Concrete 2016*. (Japan) 302 p
- [19] Barbara Klemczak, Agnieszka Knoppik-Wróbel 2011 *Architecture civil engineering environment* **4** 47-58
- [20] Aniskin N A, Nguyen T C 2020 *Magazine of civil Engineering* **99**(7) 11p.